

CEDARAPIDS®
A TEREX BRAND

Portable Plants

CRS820C
Screen Plant

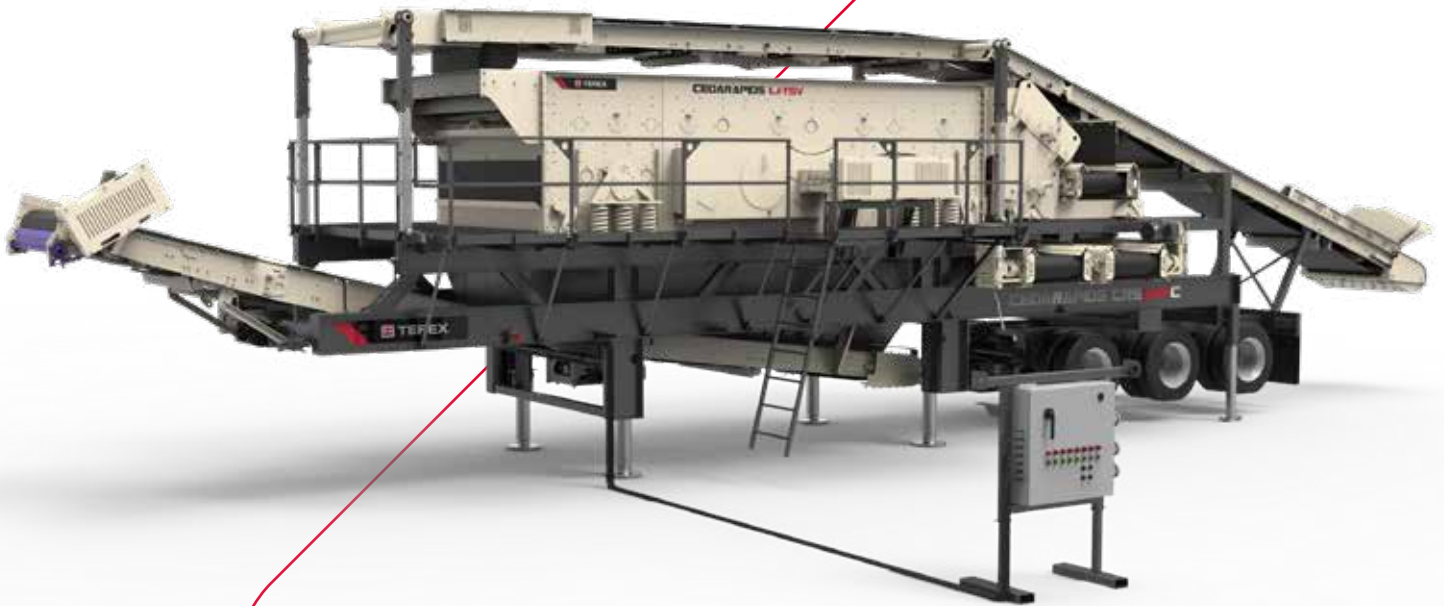

A world working better™

 **TEREX® MPS**

Cedarapids® Portable Plants

CRS820C Screen Plant

Exceptional Productivity & Efficiency

CRS820C Plant Specifications

TSV 8203 Screen

- 8' x 20' 3-deck screen

Standard Features

TSV 8203-38 heavy-duty triple-shaft El-Jay™ oval stroke screen

- Adjustable screen stroke angle and stroke length
- 5/16" (8mm) thick side plates and beam to beam braced decks
- Patent pending low maintenance surge dampeners/ship braces
- Patented triple-shaft lubrication system
- QuickLube connections for TOPS 2.0 filter system

Patented low maintenance 50 hp flex shaft screen drive

- No drive belt whip or tension idler
- No drive belt pull affecting screen movement
- Drive folds for travel without shaft disassembly

Heavy-duty roll-away blending chutes for screen cloth access

- Four section (25%) blending gates for all decks
- Combine decks: top-center, top-bottom, center-bottom, bottom-fines
- 1/4" (6mm) Removable AR400 steel liners

- Standard folding fines conveyor
- Optional hydraulic fines conveyor folds for export

Flex shaft drive folds for travel

- Roll away blending chute
- Extended Walkway option shown

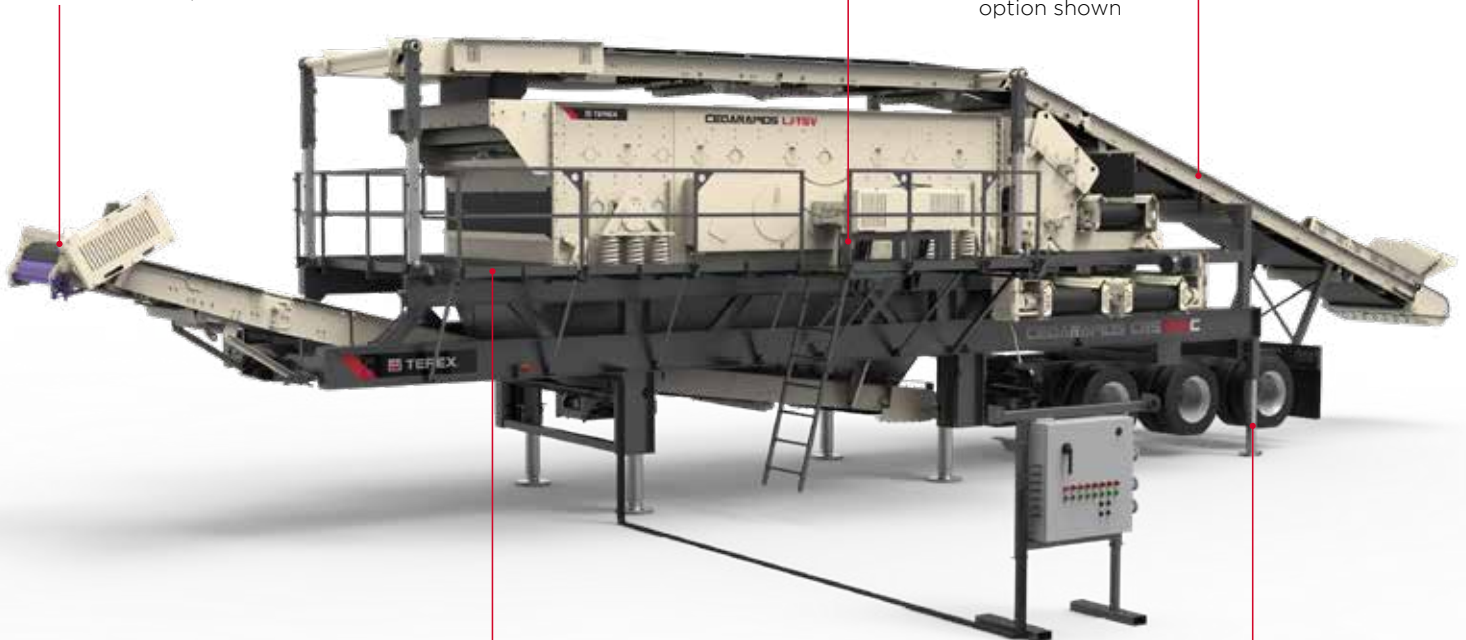

Walkways fold for travel

Standard crank style landing jacks

Rugged heavy-duty conveyor systems

- Folding Fines Conveyor Inclined 60" (1524 mm) 15 hp (11kW)
- 3 x 36"(915 mm) reversible 7.5 hp (5.6kW) cross conveyors
- 48" overhead feed conveyor 25 HP (18.6kW)
- 3 ply belts with vulcanized belt splices
- Cema C class troughing idlers and rubber disk return idlers
- Class II shaft mount gear boxes with TEFC motors
- Belt centering side roller guides
- Easy access belt take-up (end pull on cross conveyors)

Extra-wide walkways on both sides and feed end of screen

- Fold down sides for travel
- Non-skid surfaces can be shovel cleaned
- Walk around drive and screen incline
- Removable ladder

Heavy Duty I-Beam main frame

- Triple axle 25,000 lbs (11,340kg) leaf spring suspensions
- Air brakes with spring applied emergency brakes
- Lights and splash guards
- Eight 295/75 R22.5 tires and two crank-style landing jacks

Optional Equipment

- Extended walkway both sides along chutes
- Hydraulic power for roll-away chutes
- Removable switchgear panel and frame with 20' (6096 mm) extra cable and cable wraps
- Two crank style rear levelling jacks
- Four hydraulic levelling on pinned run-on jacks
- Patent pending deck deflectors boosting screen effective area
- Oversize 315/80 R22.5 tires
- 2" to 3.5" (51mm to 89 mm) convertible king pin
- Magnetic screen deck liners for cross beams and diagonal braces
- TOPS 2.0 portable oil filter system
- Hydraulic powered fines conveyor folding
- Hydraulic powered over-head conveyor raise and lower

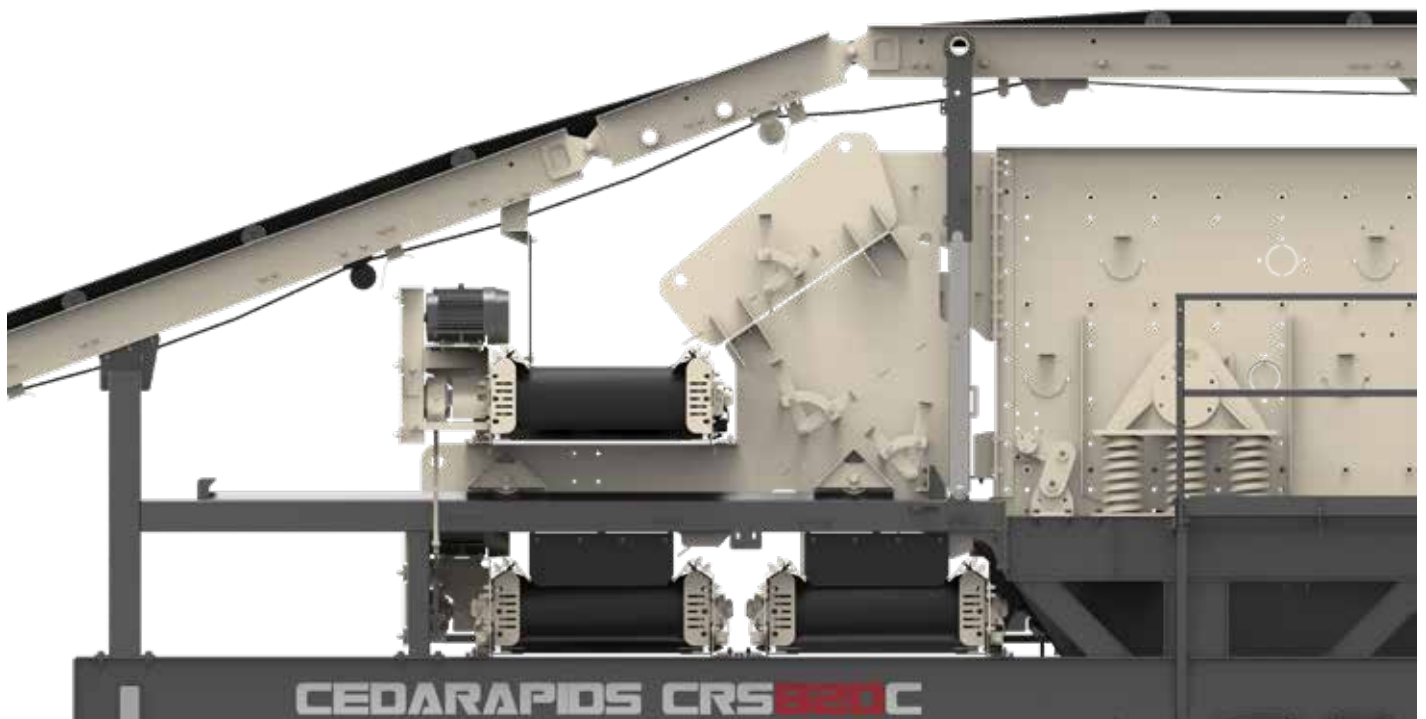

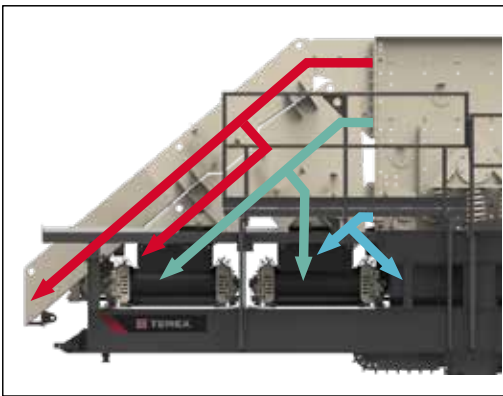
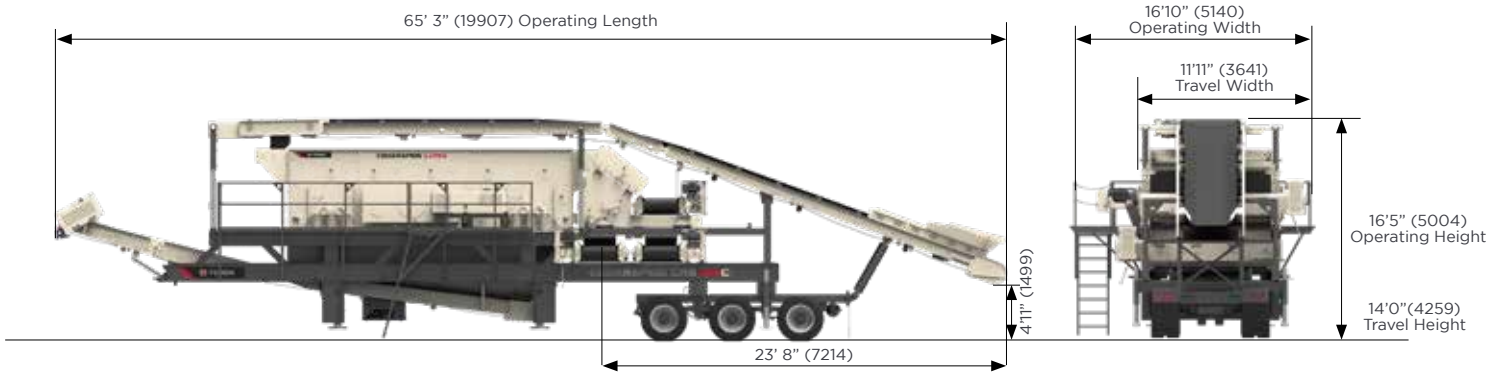

Roll Away Blending Chutes

- Roll away chutes (hydraulic optional)
- 4 section blend gates with individual handles combine any adjacent deck products in 25% increments.
- Removable 1/4" AR400 steel liners

CRS820C Specifications

CRS8203 Screen: 8' x 20' (2438 x 6096 mm)
 Underscreen Conveyor: 60" (1524 mm)
 Cross Conveyors: 36" (914 mm)
 Over Head Conveyor: 48" (1219 mm)

Horse Power

CRS8203 Screen: 50 hp (37 kW)
 Underscreen Conveyor: 15 hp (11 kW)
 Cross Conveyors 7.5 hp (5.6 kW)
 Over Head Conveyor: 25 hp (18.6 kW)

Approximate Weights

Kingpin 49,000 lbs (22273 kg)
 Rear axle 36,000 lbs (16364 kg)

www.terexmps.com
mpsmarketing@terex.com

Product specifications and prices are subject to change without notice or obligation. The photographs and/or drawings in this document are for illustrative purposes only. Refer to the appropriate Operator's Manual for instructions on the proper use of this equipment.

Failure to follow the appropriate Operator's Manual when using our equipment or failure to act responsibly may result in serious injury or death.

The only warranty applicable to our equipment is the standard written warranty applicable to the particular product and sale, and Terex makes no other warranty, express or implied. Terex, the Terex Crown design, Cedarapids, Canica, Simplicity, Jaques, El-Jay and Rollercone are trademarks of Terex Corporation or its subsidiaries. All rights are reserved. ©February 2023