

CANICA[®]
A TEREX BRAND

Canica[®]
CRV Series Impact Portable Plant



A world working better™

 **TEREX** MPS

Contents

- 01 Introduction
- 02 Key Advantages
- 03 Walkarounds
- 04 Standard Features & Benefits
- 05 Options
- 06 Chamber Details
- 07 Transport Drawings



Canica®

Flexible. Innovative. Built to Last.

Welcome to the World of Canica®

Canica® provides a comprehensive range of vertical shaft impactors to customers around the world.

Our equipment is designed to produce the highest quality end products. We provide Modular, Portable and static VSI plants and components – plus full parts, service and maintenance with support you can count on, wherever you are.

Key Benefits

- Sand manufacture
- High cubicity product
- Beneficiation of Material (elimination of soft stone)
- Gradation Consistency
- High Product Yield
- High Fracture percentage
- Simple Maintenance
- High Throughput Capacity
- Low Capital Investment

We understand your business

We know that you need operational reliability, cost effectiveness plus outstanding service. We have spent over 40 years building our business around delivering all three. Because when you succeed, we succeed.

World Class Service & Support

With Canica®, you don't just get best-in-class engineering technology. You get the service, training and support to match.

We understand your need to maximize productivity and control operating costs across the working life of every piece of equipment

We share those goals – and have the solutions to help keep your operations running smoothly, through a dedicated global support network backed by decades of proven experience and expertise.

Canica® CRV-Series Key Advantages

Key Advantages

- Heavy Duty main pedestal assembly with large spherical roller bearing to handle high capacities
- Patented hydraulic Hydralid Lid Lifter mechanism provides a safe and convenient way for one person to remotely open the lid
- Externally adjustable feed tube system allows longer feed tube life
- Lid and mainframe liners are 28% cast chrome protected
- Tungsten carbide and ceramic components in table and rotor
- Many internal crusher configuration options to provide crushing solutions for all levels of material abrasiveness
- Modular oil system includes: 35 gallon reservoir, positive displacement oil pump, low pressure relief valve and high pressure lid lifter valve, low pressure shut-down switch, oil heater, oil sight gauge, oil temperature gauge and lube oil pressure gauge
- Standard safety features include open lid safety lock, shut-off switches to detect low oil pressure, excessive vibration (vibration switch) and open lid)
- Auxiliary electrical control cabinet with tachometer/hour meter, lubrication system starter, conveyor starter, oil system heater starter, contains termination points for all safety shut off switches, warning strobe

Pinion Drive Option:

- Single or dual Horizontal motor drives
- Best access for drive belt maintenance
- Easier pulley speed changes



Note: Optional Dual horizontal motor Pinion drive shown.
Also available with single horizontal motor pinion drive.

Canica® CRV-Series Standard Features

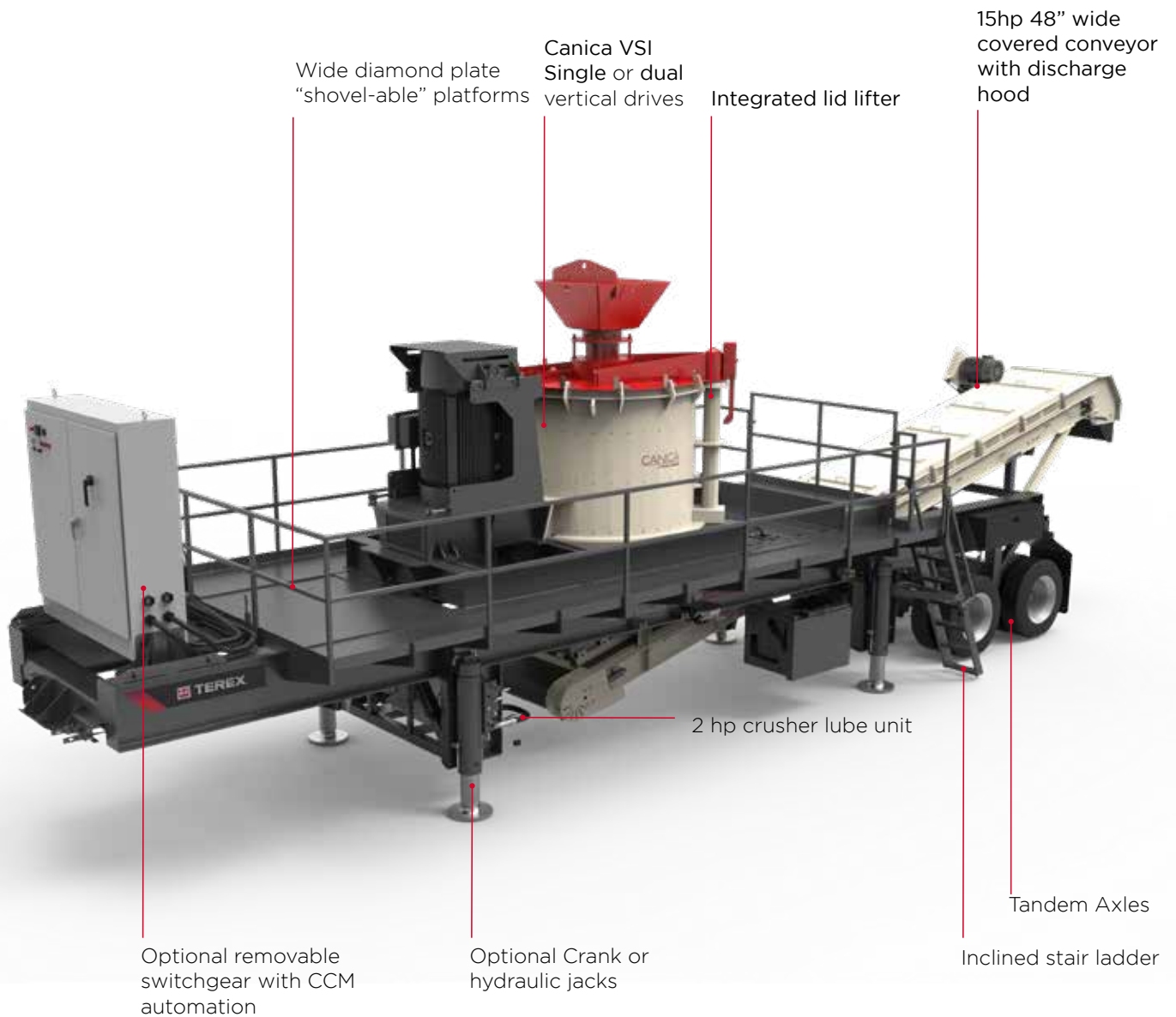

Canica® CRV-Series

How a VSI Works

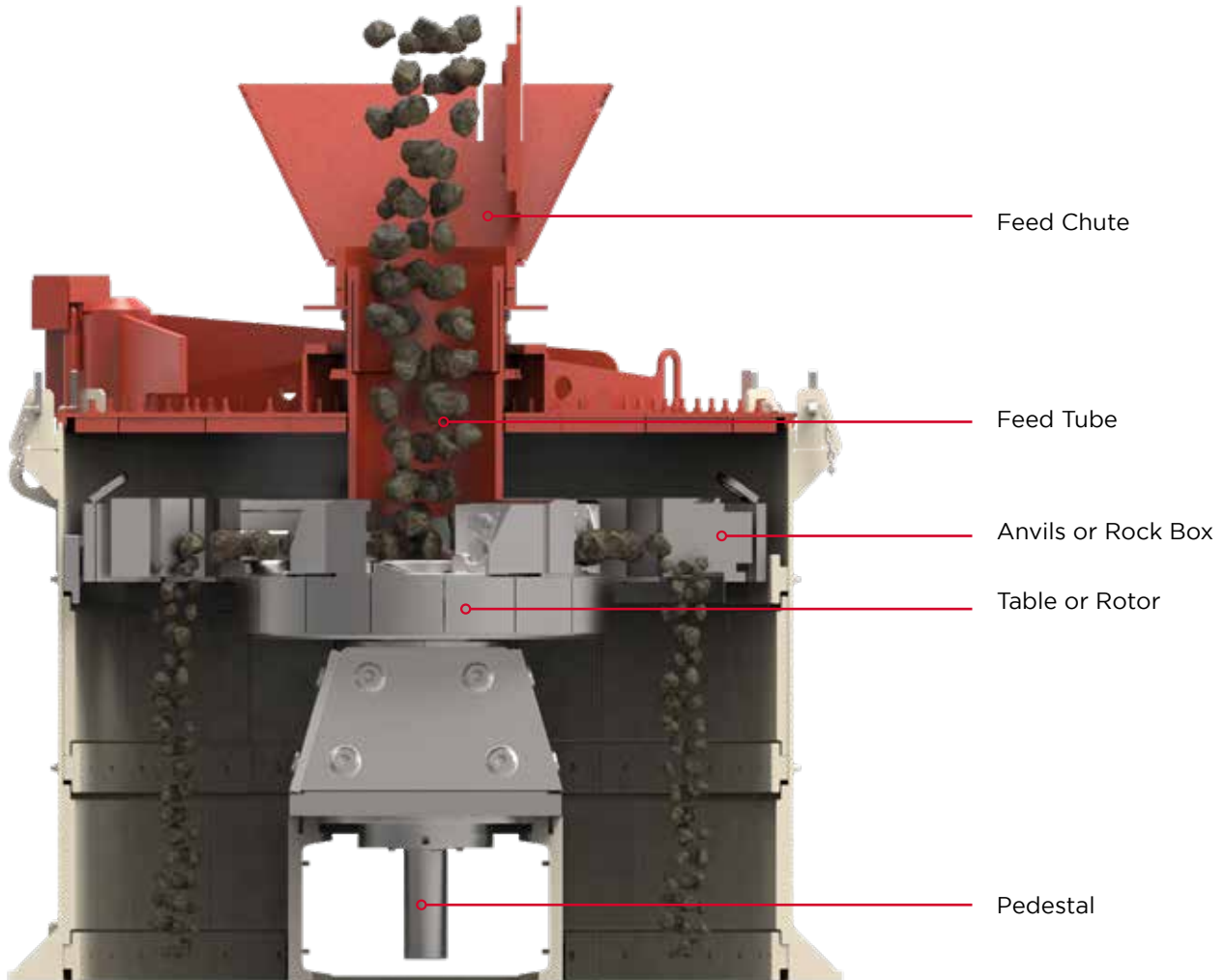

Canica® CRV-Series Standard Features

Crusher

- Available Models 2000,2050, 2350
- Heavy-duty bearing pedestal
- Astralloy main shaft
- Cast chrome pedestal protection
- Patented "Hydralid" hydraulic lid lifter
- Externally adjustable feed tube system
- Cast feed tube
- Cast lid and mainframe liners
- Heavy-duty motor mounts with motor covers and adjustable take-ups Vibration shut-off switch
- Belt guards
- Heavy-duty open shoe table
- Cast lined flywheel
- Drive belts and sheaves
- Patented vaulted anvil system
- Inspection door with safety lock

Modular Oil System

- 35 gallon (132 liter) reservoir
- Positive displacement oil pump
- Low pressure relief valve and high pressure lid lifter valve
- Low pressure shut-down switch
- Oil heater
- Oil sight gauge, oil temperature gauge, and lube oil pressure gauge
-

Ancillary Electrical Control Cabinet

- Tachometer/Hour meter
- 2 HP (1.5 kW) lubrication system starter
- 15 HP (11 kW) conveyor starter
- Oil system heater starter
- Contains termination points for ALL safety shut-off switches Warning strobe

Standard Safety Features

- Open lid safety lock
- Shut-off switches detect: Low oil pressure, Excessive vibration (vibration switch), Open lid

Crusher Optional Equipment

- Two-piece crusher design (removable tub section)
- Pinion gear drive assembly
- 4 and 5-port autogenous rotors
- 4 and 5-port anvil ring rotors
- Rockbox
- Ceramic wear parts
- Tungsten carbide wear parts
- Portable chassis mount
- Stationary support stand with walkways and ladders Diesel power
- Variable frequency drives
- Soft starts

Plant Optional Equipment

- 300 hp (single 300) to 700 hp (dual 350)
- CCM automated switchgear panel with crusher soft start
- Tether control, radio remote, inter-plant communication
- Variable frequency crusher drive in place of soft start
- Metal detector
- Hydraulic leveling or run-on jacks
- Dust suppression & pump
- Oversize tires

Canica® CRV-Series Interchangeable Crushing Chambers

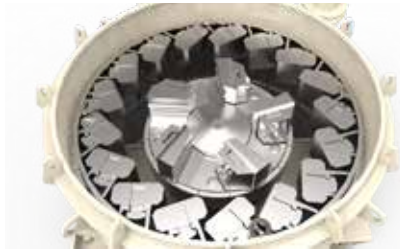

Shoe and Anvil
(HD Series)



Rock and Anvil
(ROS Series)



Rock on Rock
(ROR Series)



Large Feed, Mild to Medium
Abrasive Materials

Shoe and anvil configuration offers high tonnage of chip production, high reduction ratios and feed size flexibility.



High Reduction in Medium
Abrasive Materials

Enclosed rotor and anvils combine the grinding action of the rotor with the high efficiency reduction of anvils.



For All Rock Types and the
Most Abrasive Materials

Enclosed rotor and rock box configuration causes rock on rock crushing which produces the best shaped and most consistent material with the lowest wear cost.

Model	2000	2050	2300	2350
Maximum Feed Size Largest Dimension, Open Table Configuration	4" 102 mm	4" 102 mm	5" 127 mm	6" & 8" 152 mm & 203 mm
Maximum Through-put Capacity (TPH) Feed size and tons per hour dependent on type of feed and HP available	UP TO 300 TPH	400 TPH	500 TPH	600 TPH
Horsepower for Maximum Through-put Depending on application	200-400 HP	400-700 HP	400-700 HP	300-700 HP

Only the following 3 models 2000, 2050 & the 2350 are currently available in the CRV wheeled format.
Optional 300hp variable speed drive available.

Canica® CRV-Series Technical Drawings

Transport and Working Dimensions

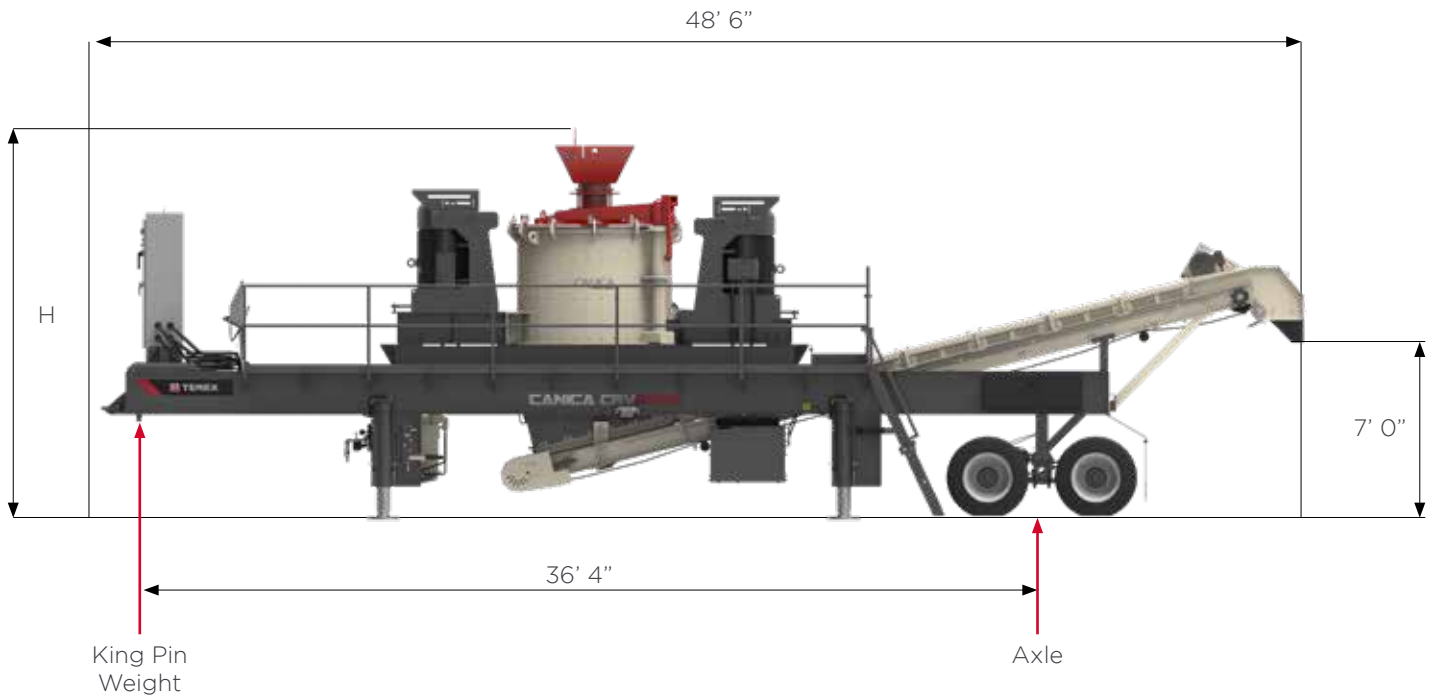

Model	Width	H (Height)		Weight (lbs) **	
		with Hopper	No Hopper	King Pin	Axles
CRV2000		14' 4"	12' 10"	36,019	34,284
CRV2050	11' 11"	14' 7"	13' 3"	36,663	34,940
CRV2350		14' 9"	13' 4"	37,511	35,803

Hopper can be removed for Transport

Canica® CRV-Series Canica VSI Applications

		Open Shoe Table Anvils	Rotor/Anvils	Rotor / Rockshelf
Relative Abrasiveness	Very High			
	High			
	Medium			
	Medium Low			
	Low			
Max Feed Size	CRV 2000, 2050	4"	2- 1/2"	
	CRV 2350	8"	2- 1/2"	



Single horizontal motor pinion drive shown

Canica® Services

Proven Success, Global Reach

A complete range of services. Original spare and wear parts. Customizable solutions to meet your exact needs. Outstanding technical expertise and support.

This is what Canica® delivers to businesses – and what it delivers to businesses throughout the world via our global distribution network, service and distribution facilities and regional warehouses.

Spare and Wear Part Support

Our OEM parts help maintain and enhance the performance of your equipment – and you can count on us to get you the spare and wear parts you need, when you need them.

Canica® parts are manufactured according to exacting specifications, using high-quality materials, tools and techniques. By using genuine parts you are helping to ensure the maximum performance and longevity of your machines.

A Shared Focus

We understand your key focus is delivering your operational and financial goals. We share that focus: it's how we both measure success.

By combining our global service network and proven, in-depth industry knowledge with your operational expertise we're able to provide you with the right solution to deliver a quality end product – with increased productivity.

Field Services

We offer a comprehensive set of field services to meet your maintenance, repair and refurbishment needs – which means you get a cost-effective alternative to purchasing new or replacement equipment.

Our experienced field service and distribution network are available to you on site or at our global service facilities. We can repair broken or damaged equipment to like-new condition and restore worn or irreplaceable equipment to perfect operating condition – which minimizes costly downtime for you.

Terex® Financial Services

At Canica® we not only offer a strong and broad product portfolio. We also offer the means for customers to purchase the equipment they need in order to meet their operational and profitability goals.

Terex® Financial Services (TFS) is a globally trusted resource that is able to leverage its knowledge of Terex® equipment plus its marketplace expertise to provide a unique tailored solution for customers.

Terex® Financial Services at a Glance

- Providing cost-effective financial solutions to thousands of customers across the globe
- A comprehensive suite of financial solutions tailored to fit individual needs
- Dedicated and knowledgeable team with global reach, focused on customer solutions.

Combining our global service network and deep industry knowledge with your operational expertise ensures that we provide the best solutions...



North America

3900 Fountains Blvd NE, Suite 101
Cedar Rapids, IA 52411
Tel: +1 319 363 3511 or +1 800 821 5600
Fax: +1 319 399 4871

212 South Oak Street
Durand, MI 48429
Tel: +1 989 288 3121
Fax: +1 989 288 4113

Europe, Russia & Africa

Farlough Road, Dungannon
Northern Ireland. BT71 4DT
Tel: +44 (0) 28 8744 0795

Central Asia, Turkey & North Africa Region

Mehmet Akif Ersoy Mah.287.SkNo 1/D
06172 Yenimahalle - Ankara Turkey
Tel: +90 312 354 90 90

Australia

Melbourne & Victoria
133 Logis Boulevard
Dandenong South, VIC 3175
Tel: +61 3 8794 4100
Fax: +61 3 9706 7810

Sydney & New South Wales
114 Hassall Street
Wetherill Park, NSW 2164
Tel: +61 2 9604 6524
Fax: +61 2 9604 9368

Brisbane & Queensland
585 Curtin Avenue East
Eagle Farm, QLD 4009
Tel: +61 7 3630 0866
Fax: +61 7 3630 1097

Perth & Western Australia
4 Miles Road
Kewdale, WA 6105
Tel: +61 8 6254 4100
Fax: +61 8 9350 5534

www.terexmps.com

Product Specifications and prices are subject to change without notice or obligations. The photographs and/or drawings in this document are for illustrative purposes only. Refer to the appropriate Operator's Manual for instructions on the proper use of equipment. Failure to follow the appropriate Operator's Manual when using our equipment or failure to act responsibly may result in serious injury or death. The only warranty application to our equipment is the standard written warranty to the particular product and sale and Terex makes no other warranty, express or implied.

Terex, the Terex Crown design, Cedarapids, Canica, Simplicity, Jaques are trademarks of Terex Corporation or its subsidiaries. All rights are reserved.

© June 2019 Terex Minerals Processing Systems.

