

# CEDARAPIDS<sup>®</sup>

A TEREX BRAND

## Portable Cone Plant

CRC420

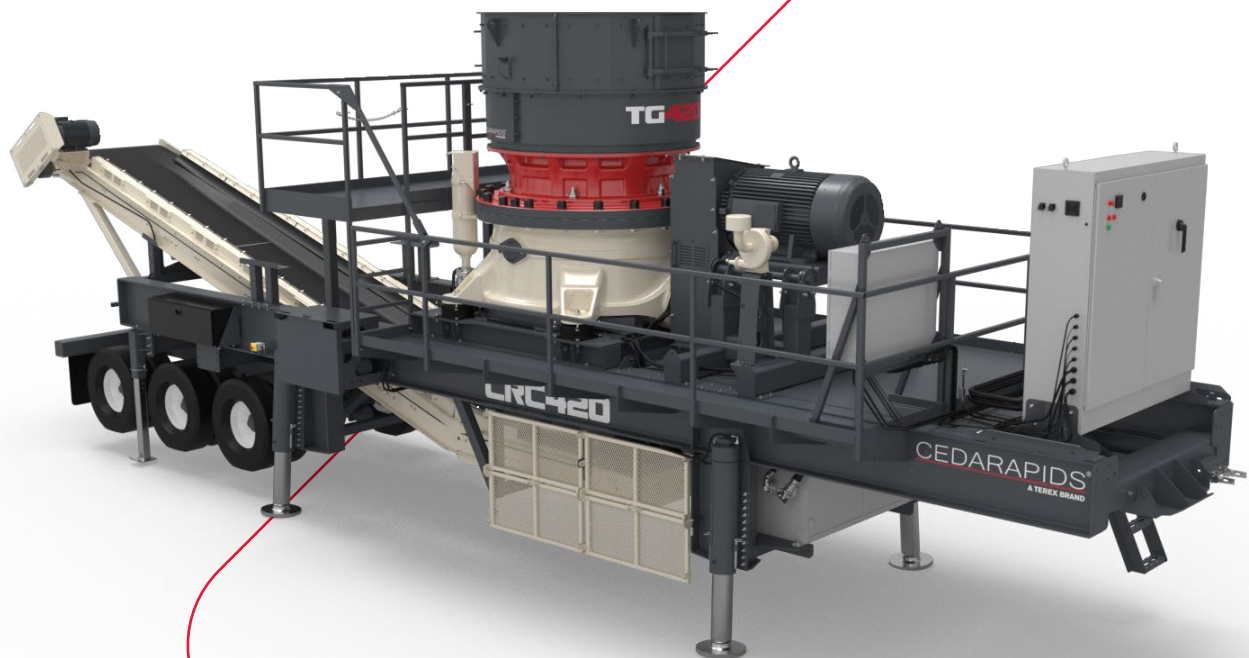

A world working better™

 **TEREX**.MPS

# Cedarapids® Portable Plants

## CRC420 Portable Cone Plant

The CRC420 portable cone plant features the TG420 cone with a large feed opening. The all electric plant fits a variety of layouts and applications and is designed for easy transport on the road or on site. Service platforms with wide walkways allow easy and safe access for maintenance and inspection. The bronze bushing technology of the TG420 cone enables the operator to quickly and easily alter the eccentric throw of the cone, on site, simply by rotating the eccentric bushing.

### Standard Features

- TG420 bronze bushing cone
- 400 hp (300 kW) 1800 rpm crusher motor
- Oversize cone feeder hopper extension with removable overflow panel
- 48" (1219 mm), 3-ply conveyor belt with vulcanized belt splice and primary style belt wiper driven by a 15 hp (11kW) electric motor and shaft mount gearbox
- Service platforms with elevated deck, guard rails and access ladder
- Easy maintenance features:
  - remote grease lines
  - ground access cone lubrication module
- Emergency stop buttons on both sides of frame
- Triple axle spring suspension with twelve 295/75 R22.5 tires
- 48" (1219 mm) long lockable side-mounted storage box

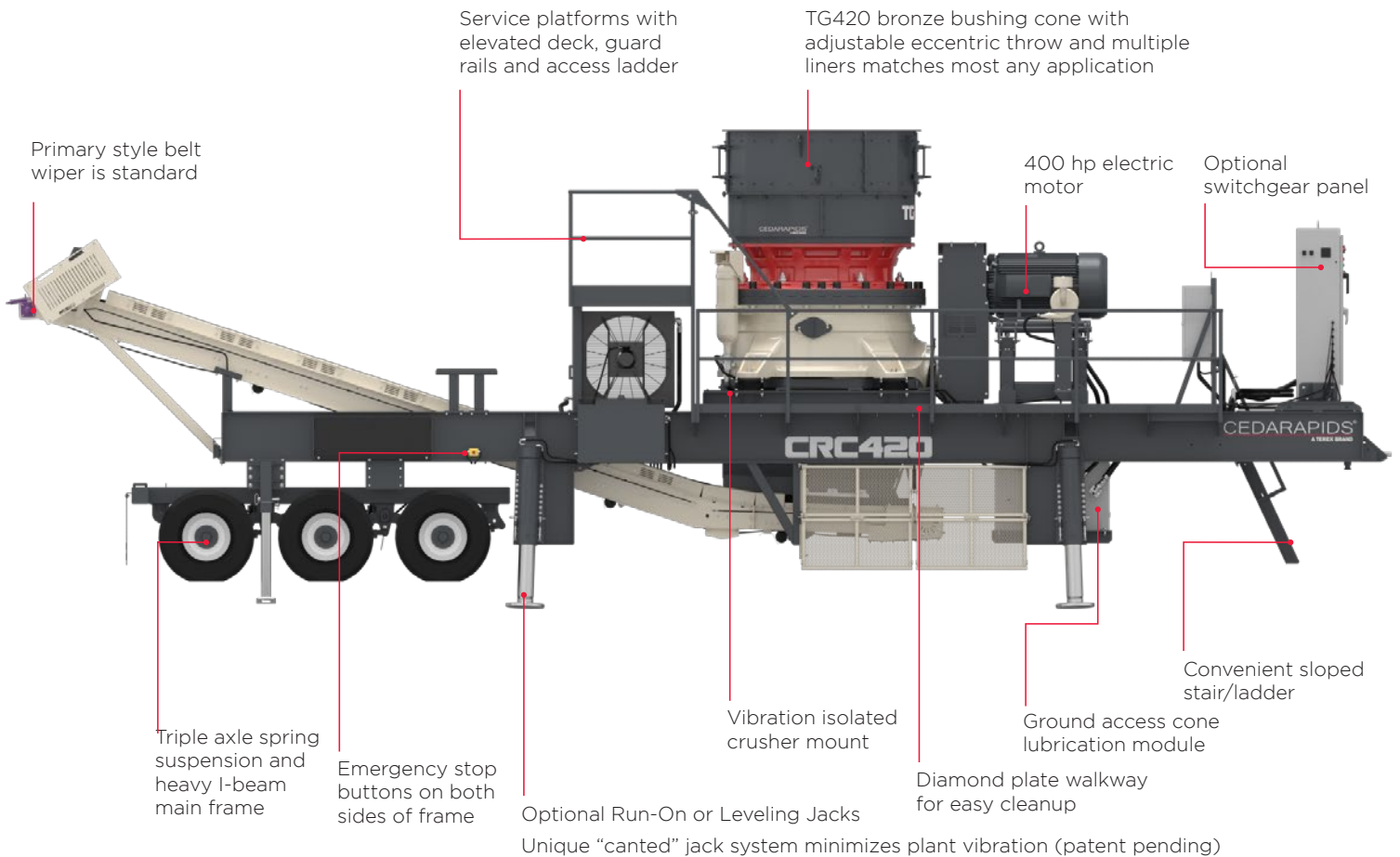

Power Requirements	hp	kW
Cone	400	300
Conveyor	15	11

### Optional Equipment

- Overflow chute
- Removable switchgear panel
- Four 18" stroke leveling jacks
- Four 24" stroke run-on jacks
- Hydraulic Power Unit (Gas, 12V, 24V)

### Working Dimensions

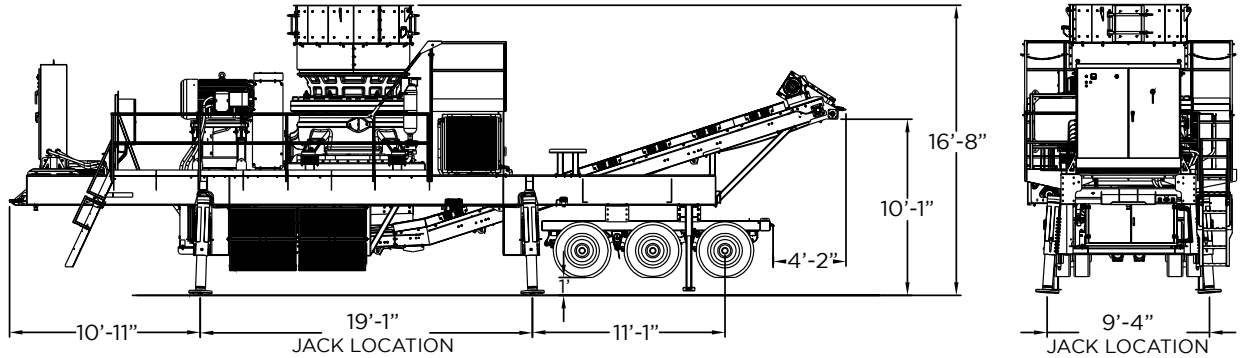

### Transport Dimensions

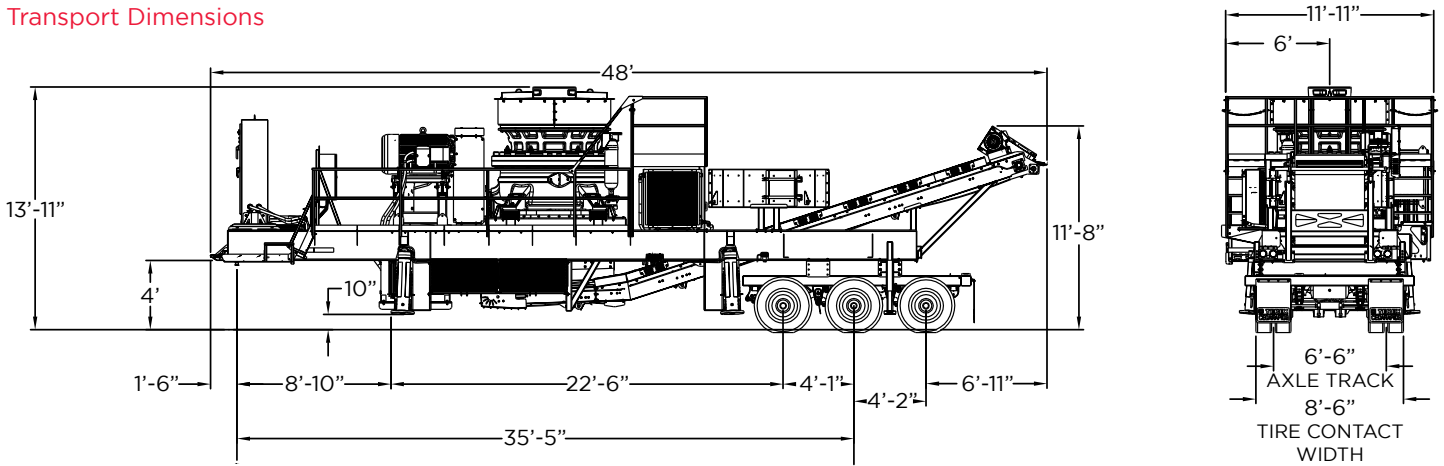

	Kingpin Weights	Axle Weights	Total Weights
Base Plant plus optional electric power panel and 4 run-on jacks	45,794 lb	52,871 lb	98,665 lb

#### Note:

- Standard tires 295/75R22.5 (315/85R22.5 optional)
- spring applied brakes
- 2" king pin dia

Weights and dimensions are calculated values and are subject to change.

Please consult bill of lading for actual shipping weights and dimensions.

Weights shown do not guarantee legal shipping weights and dimensions in all locations.

Please consult local and state regulations for legal shipping weights and dimensions.

[www.terexmps.com](http://www.terexmps.com)

Product specifications and prices are subject to change without notice or obligation. The photographs and/or drawings in this document are for illustrative purposes only. Refer to the appropriate Operator's Manual for instructions on the proper use of this equipment.

Failure to follow the appropriate Operator's Manual when using our equipment or failure to act responsibly may result in serious injury or death.

The only warranty applicable to our equipment is the standard written warranty applicable to the particular product and sale, and Terex makes no other warranty, express or implied. Terex, the Terex Crown design, Cedarapids, Canica, Simplicity, Jaques, El-Jay and Rollercone are trademarks of Terex Corporation or its subsidiaries. All rights are reserved. © October 2021

