

FINESMASTER

FM ULTRAFINES

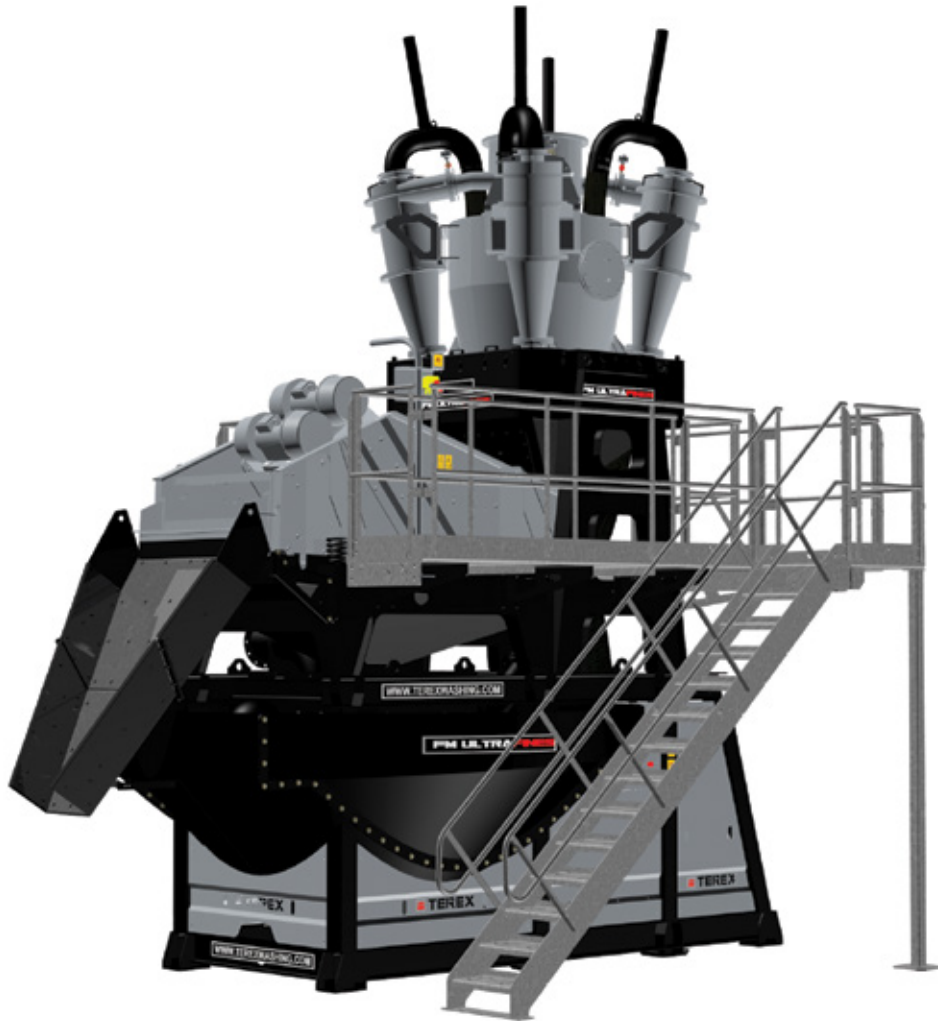

KEY FEATURES

- Modular Compact Unit
- Containerised Transport
- Pre Wired & Pre Plumbed
- Quick Set Up
- 1 Electrical Connection Point
- 1 Water Connection Point



AGGREGATES



RECYCLING



INDUSTRIAL SANDS



MINING

FM UltraFines

KEY FEATURES AND BENEFITS

- Cluster of 4 no. T375 cyclones with drop-in replaceable liners
- Single 12" overflow discharge connection
- Fully galvanised access walkways for maintenance of dewatering screen & cyclone spigots.
- Intelligent symmetrical design allows assembly to suit left or right access.
- Single 10" rubber lined feed point can be configured left or right to suit site set up.
- Anti-turbulence feed box provides controlled wearing & reduced settling time.
- Conical tank design eliminates risk of fines build up.
- Bolt-on sides allow simple containerisation and site set-up.
- 200/150 pump complete with 30kW electric motor.
- Replaceable rubber liners for extended wear-life.



- Lift out pump feature for easy maintenance.

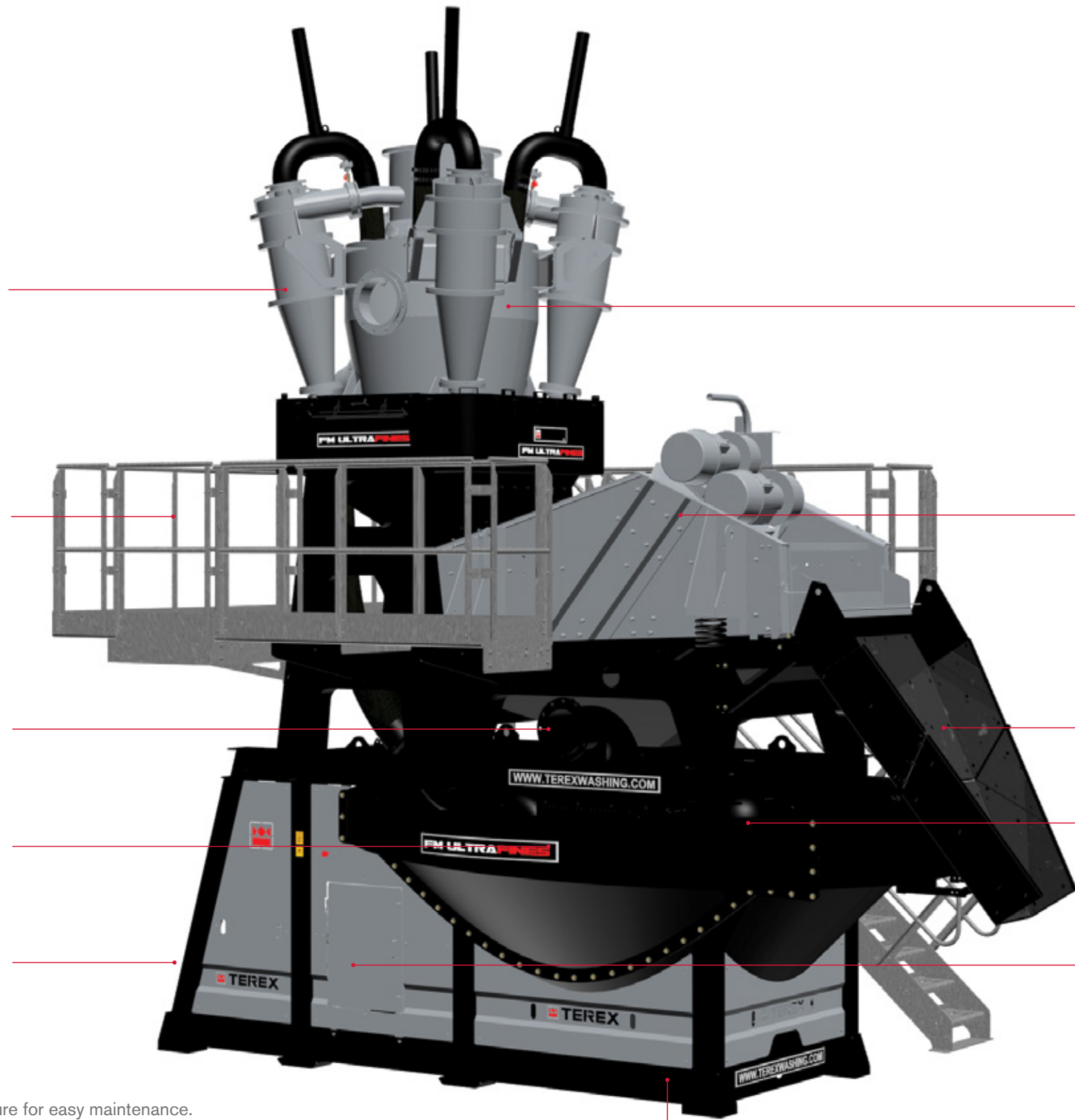

APPLICATIONS

- AGGREGATES
- RECYCLING
- INDUSTRIAL SANDS

- Fully lined cyclone discharge box for increased wear-life.
- Quick release lids for inspection and maintenance.
- 2.4 m x 1.2m (8'x4') high frequency dewatering screen optimising superior moisture reduction.
- Full width PU media for quick change outs.
- Low friction discharge chute with angle adjustment.
- Self regulating float level system provides consistent tank volume and pump run-dry protection.
- Wired to isolators or fully enclosed control panel to integrate with other TWS equipment.
- Raised chassis design for wash down.

CHASSIS/TANK

- Heavy duty integrated tank & chassis
- 3.6m conical sump tank with all-round weir
- 9m³ volume
- Tank splits both sides for transport and containerisation
- 10" (PN10) single feed point



CYCLONE CLUSTER

- Cluster of 4 no. T375 rubber lined cyclones
- Drop-in replaceable liners
- Rubber lined underflow box - c/w quick release lid
- Single 12" (PN10) overflow discharge connection



TRANSPORT

- Ships in 2 open-top containers - 1 x 40' and 1 x 20'



WALKWAY

- Fully galvanised, reversible walkways
- Expanded metal floors
- 600mm (24") wide
- Walkway around both sides of the machine



DEWATERING SCREEN

- High frequency (2.4m x 1.2m) dewatering screen
- 2 x 2.3kW vibratory motors
- Polyurethane modules and side protection
- Polyurethane low friction wear lining in discharge chute

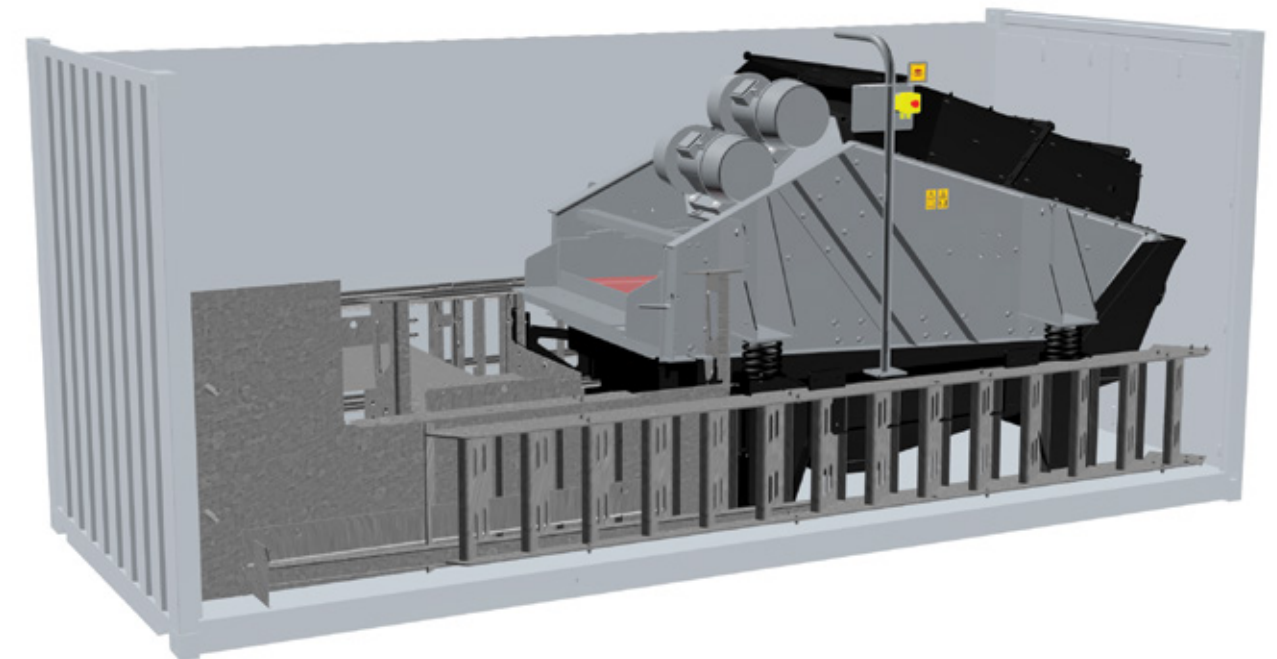

DIMENSIONS

WORKING DIMENSIONS

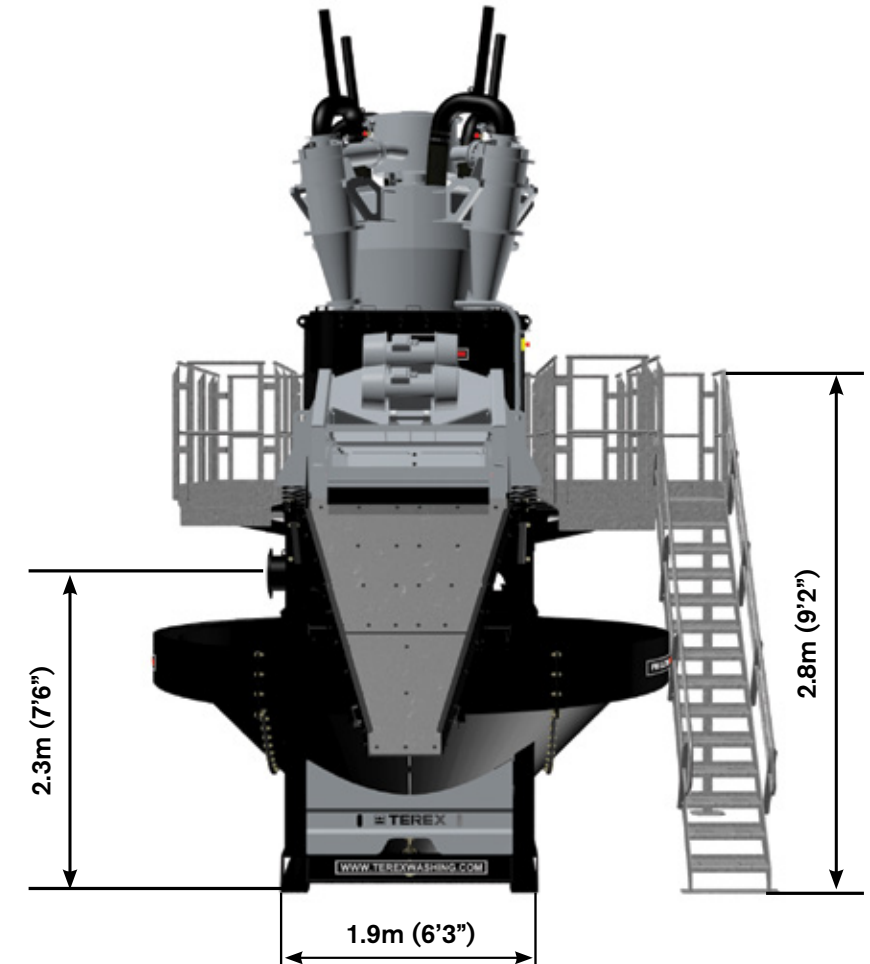
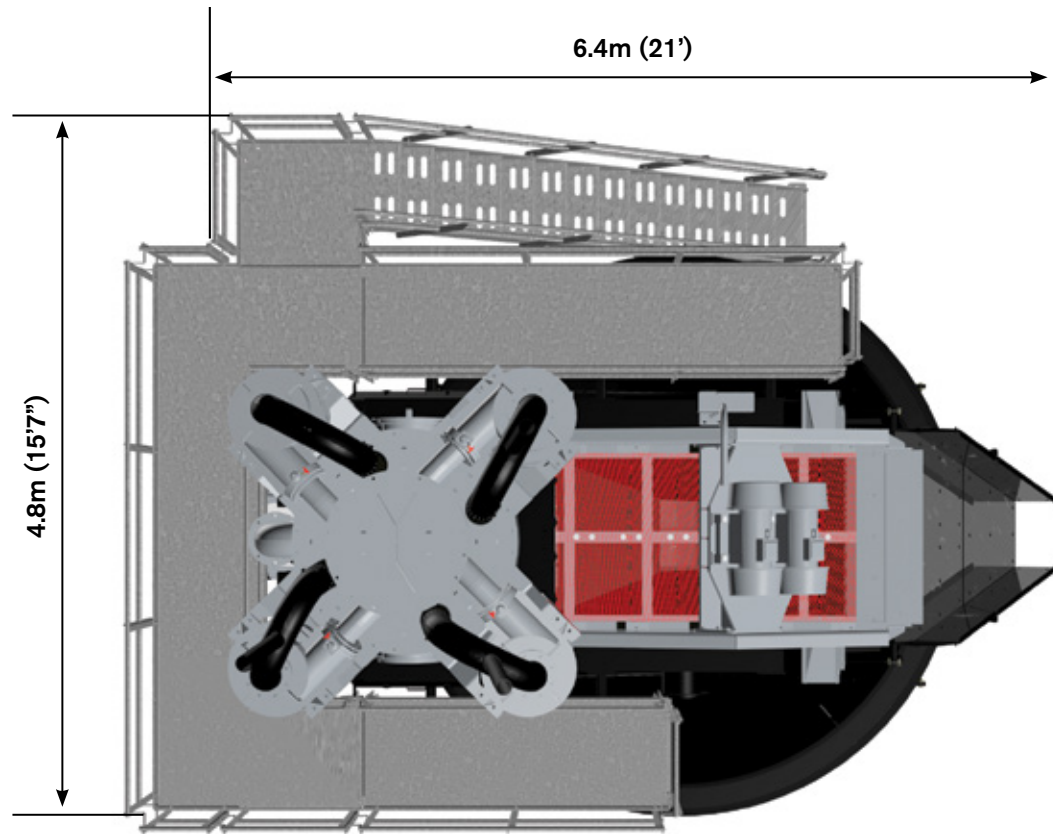
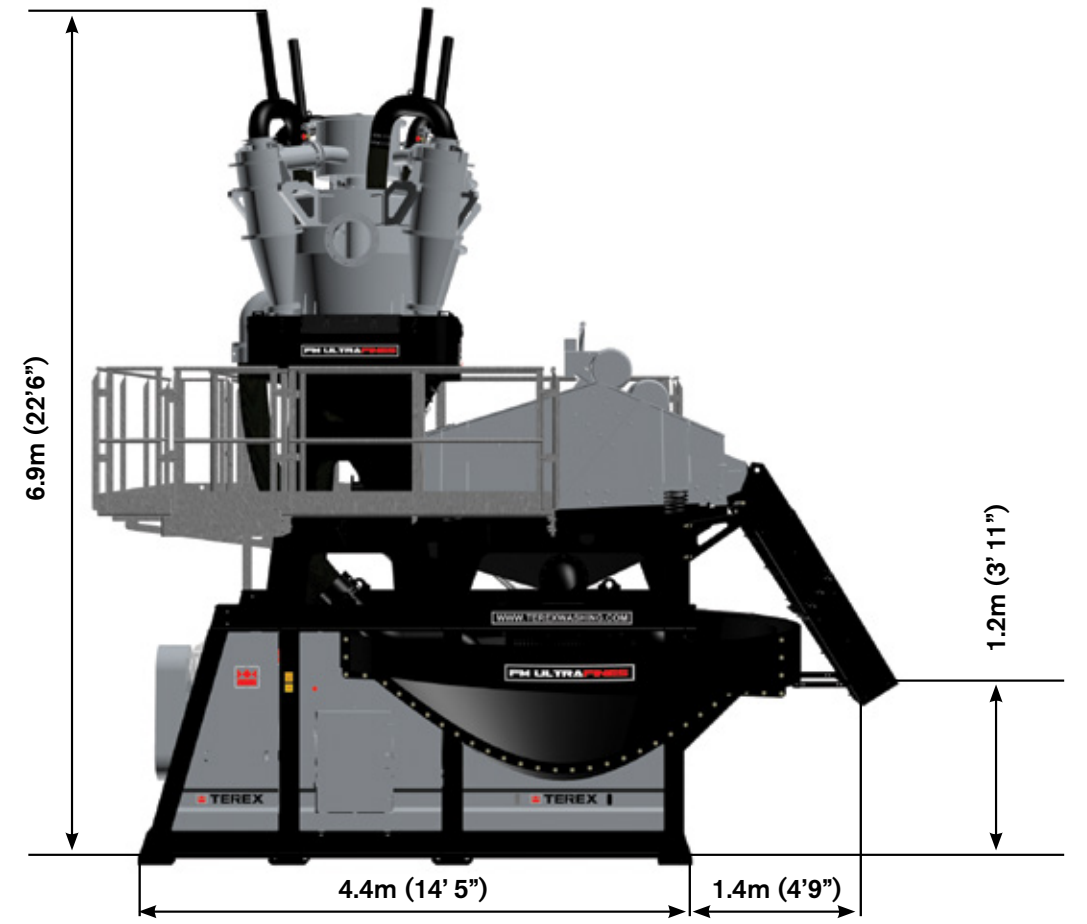

TEREX WASHING SYSTEMS CONTACT DETAILS

Dungannon Site

200 Coalisland Road
Dungannon
Co. Tyrone
Northern Ireland
BT71 4DR

Tel: +44(0) 28 8771 8500

Email: TWS.sales@terex.com

www.terex.com/washing

Linked  YouTube

Check out Terex Washing Systems videos
on YouTube: www.youtube.com/terexwashingsystems

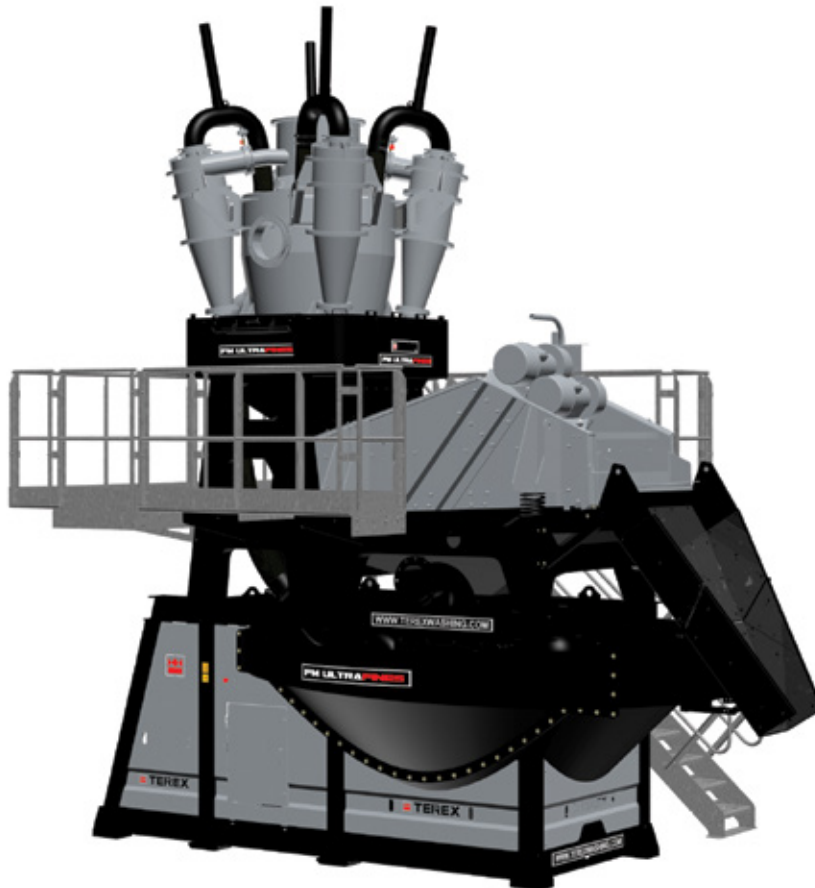

Effective Date: March 2016 Product specifications and prices are subject to change without notice or obligation. The photographs and/or drawings in this document are for illustrative purposes only. Refer to the appropriate Operator's Manual for instructions on the proper use of this equipment. Failure to follow the appropriate Operator's Manual when using our equipment or to otherwise act irresponsibly may result in serious injury or death. The only warranty applicable to our equipment is the standard written warranty applicable to the particular product and sale and Terex makes no other warranty, express or implied. Products and services listed may be trademarks, service marks, or trade names of Terex Corporation and/or its subsidiaries in the USA and other countries. All rights are reserved. Terex is a registered trademark of Terex Corporation in the USA and many other countries. © 2010 Terex Corporation.

 **TEREX**[®]
WASHING SYSTEMS

WASHING AS IT SHOULD BE